

COMPONENTS FUNCTION LOCATION CONTACTS

2CR	CONTROL RELAY	32	14,17,24,32,38,40
3CR	MANUAL START RELAY	35	26,33,36
5CR	DRIVE FAULT RELAY	42	17,38,49
6CR	CONTROLLED STOP RELAY	26	18,31,32,35
10CR	1MC DELAY RELAY	38	14
12CR	PRESSURE SWITCH RELAY	22	26,34
1PR	POWER FAILURE RELAY	46	13,16
2PR	PHASE REVERSAL RELAY	48	30,32
1TR	MINIMUM RUN TIMER	24	26
2TR	BYPASS TIMER	33	40
4TR	DRIVE FAULT TIMER	41	42
5TR	STOP RESET TIMER	29	30
1MC	BY-PASS CONTACTOR	14	3,5,7
2MC	MOTOR ACCELERATING CT.	17	4,6,8
1CB	CIRCUIT BREAKER	5,6,7	21
1MCA	1MC AUX CONTACT	17,19,26	
2MCA	2MC AUX CONTACT	51	
1CS	COAST STOP SWITCH	23	
2CS	START SWITCH	35	
3CS	SOFT STOP SWITCH	30	
1IS	ISOLATION SWITCH	5,6,7	
1PS	PRESSURE SWITCH	22	
1PL	POWER ON LIGHT	10	
2PL	PHASE REVERSAL LIGHT	47	
4PL	DRIVE FAULT LIGHT	49	
1CPT	CONTROL POWER TRANSFORMER	19	
1PM	POWER MONITOR	1	46,47
1LS	EMERGENCY START LIMIT SWITCH	15	
CVD1	NORM. CURRENT/VOLTAGE DISPLAY	1,37	
SA	SURGE ARRESTOR	8	
1SS	SOFT START	45	
10CM	OVERCURRENT MONITOR	8,50	21,33,35
1CT	CURRENT TRANSFORMER	5	
2CT	CURRENT TRANSFORMER	6	
3CT	CURRENT TRANSFORMER	7	

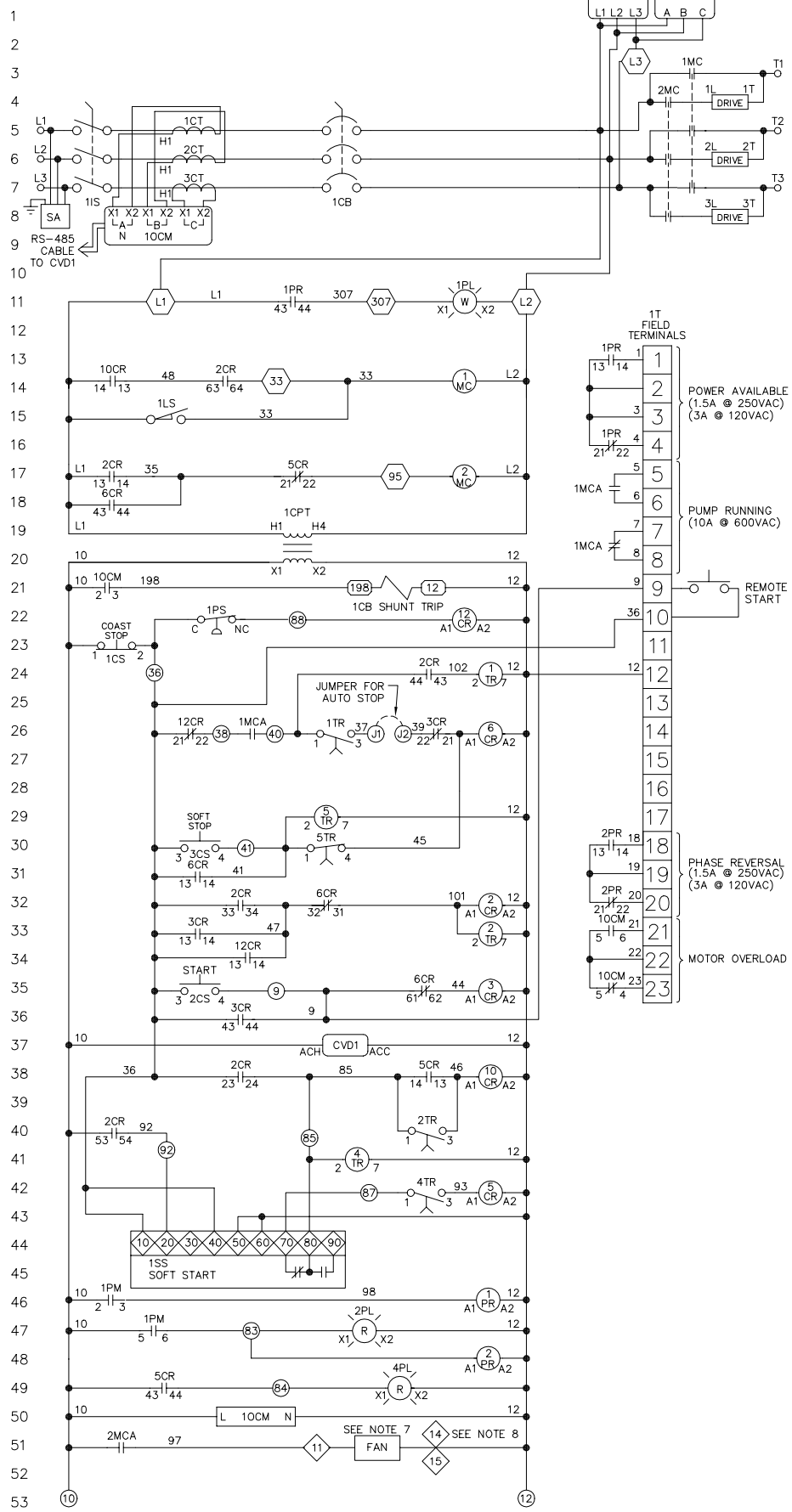

NOTES FOR FIELD WIRING
 USE COPPER WIRING ONLY EXCEPT AT TERMINALS MARKED CU-AL. ALL 1T FIELD TERMINAL CONTACTS RATED 10A @ 600VAC.

- DENOTES TERMINALS ON 1T TERMINAL STRIP.
- DENOTES TERMINALS ON 2T TERMINAL STRIP.
- DENOTES TERMINALS ON 3T TERMINAL STRIP.
- DENOTES TERMINALS ON 4T TERMINAL STRIP.
- DENOTES TERMINALS ON SOFT START UNIT.

54A SOFT START DOES NOT UTILIZE A COOLING FAN AND ASSOCIATED CONTROL CIRCUIT.
 COOLING FAN TERMINAL NUMBERS ON SOFT START UNIT WILL VARY WITH MODEL USED.
 TERMINAL #14 IS USED FOR 97A & 135A SOFT START MODELS.
 TERMINAL #15 IS USED FOR ALL OTHERS UNLESS OTHERWISE SPECIFIED.

	DRAWN SR 2-20-98	METRON, INC. DENVER, CO.
	CHECK KH 2-21-98	
	APPD X.S. 2-21-98	
SCHEMATIC, MODEL M700 SOFT START/STOP COMBINED MANUAL - AUTOMATIC ELECTRIC FIRE PUMP CONTROLLER		CS32977D
		SCALE N.T.S. SHEET 1 OF 1